

# TECHNICAL DATA SHEET "B8033FXS"

10 – 15 – 20 kVA

3Ph<sub>(In)</sub> – 3Ph<sub>(Out)</sub>

## GENERAL INFORMATION

POWER	kVA	10	15	20
UPS Type		ON LINE – Double Conversion		
Nominal output power (Cosφ 0.9)	kVA	10	15	20
Nominal output power (Cosφ 1.0)	kW	9	13.5	18
Efficiency (AC ÷ AC) (ON LINE - Double Conversion)	@25% load	> 88		
	@50% load	> 90		
	@75% load	> 91		
	@100% load	> 92		
Efficiency (AC ÷ AC) (Eco Mode)	%	> 98		
Heat dissipation at nominal load and voltage	kW	0.782	1.170	1.564
	kcal/h	0.673	1.005	1.344
UPS ambient temperature	°C	0 ÷ 40		
BATTERY ambient temperature	°C	0 ÷ +25		
UPS storage temperature	°C	-10 ÷ +70		
BATTERY storage temperature	°C	-10 ÷ +60		
Relative humidity (non condensing)	%	< 95		
Altitude	m	< 1000 (above sea level)		
Power derating for altitude > 1000 m		According to "IEC62040-3" 0,5% power derating every 100m above 1000m up to max 2000m		
Ventilation		Forced		
Requested cooling air volume	m <sup>3</sup> /h	500	500	600
Audible noise level (according to IEC EN 62040-3)	dB	< 52 db		
Standard battery type lead acid	n° cells	2 x 180		
		2 X 186		
Protection degree		IP 20		
Electromagnetic compatibility EMI		According to "IEC EN 62040-2" (CE marking)		
Safety		IEC EN 62040-1		
Test and performance		IEC EN 62040-3		
Paint		RAL 7016		
Accessibility		Front and top		
Installation		10 cm from the wall		
Dimensions	mm	L = 450 P = 640 H = 1200		
Weight (with battery)	kg	Min.175	Min. 260	Min. 260
		Max. 285	Max. 275	Max. 275
Weight (without battery)	kg	100	110	110
Static load (with battery)	kg/m <sup>2</sup>	Min. 570	Min. 829	Min. 829
		Max. 945	Max. 895	Max. 895
Static load (without battery)	kg/m <sup>2</sup>	315	348	348
Input/Output cable connection		Bottom side		
Transport		By wheels		
Transport mechanical stress		According to "IEC EN 62040-3"		
Design standards		"IEC EN 62040" "ISO 9001:2008" - "ISO 14001"		

Rev.	Descrizione Description	Data Date	Emesso Issued	Approvato Approved	Lingua Language	Pagina Page	di Pag. of Pag.
C	General upgrade	25.07.14	E. Biancucci	F. Berli	E	1	6
					Codice / Code		
					<b>OMD94010</b>		

Free contact interface		On request
Serial communication interface		Standard: RS232 - USB Optional: RS485 (ModBus protocol)
Parallel configuration (optional)		Up to 5+1 (Redundant parallel) Up to 6 (Power parallel)

## BLOCK DIAGRAM

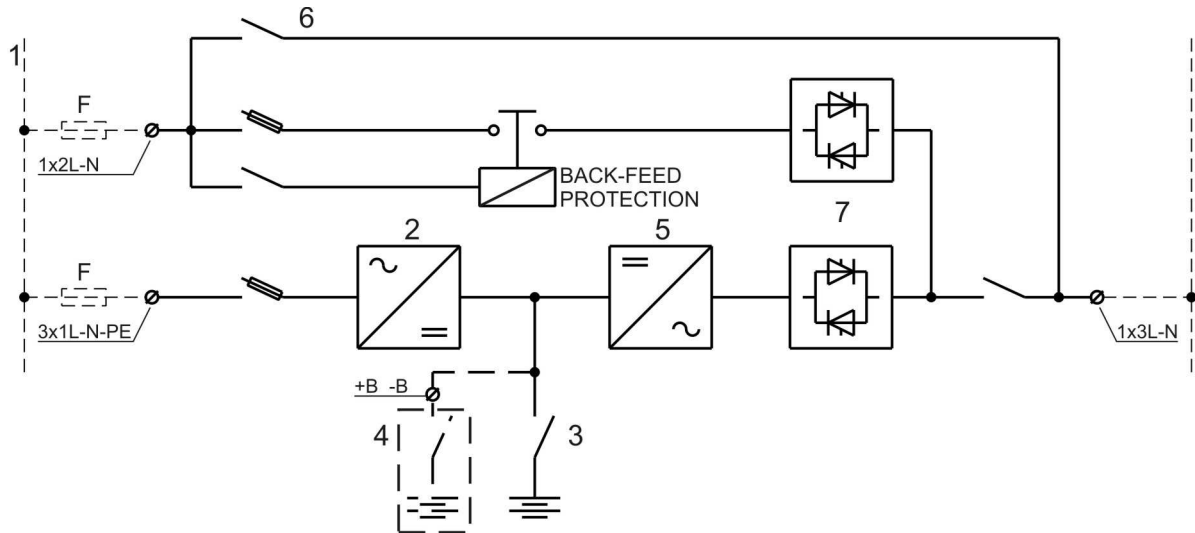

1. Input mains (separate for by-pass and rectifier)
2. Rectifier and battery charger
3. Maximum internal battery: 3,3Ah, 7,2Ah and 9Ah – 60 or 62 batteries
4. Optional external battery
5. Inverter
6. Emergency line (backfeed protection standard feature) and manual bypass
7. Inverter (SSI) and by-pass (SSB) static switch

## UPS INPUT: RECTIFIER AND BATTERY CHARGER

POWER		kVA	10	15	20
Input			Three-phase + Neutral		
Nominal input voltage range		Vac %	400 -20/+15		
Input frequency range		Hz %	50 – 60 ±5 / ±10 adjustable		
Input power factor			> 0.99		
Input current THD at nominal voltage and THDV <0.5%	@25% load	%	13 <		
	@50% load		7 <		
	@75% load		5 <		
	@100% load		3 <		
DC output voltage accuracy		%	+/- 1%		
DC output voltage ripple		% rms	1% rms		
Battery recharging characteristic			IU (DIN 41773)		
Maximum recharging current - at nominal load		A	6	10	6
Bridge rectifier type			IGBT PFC		
Input protection			Fuses		
Inrush input current		A	< maximum nominal current		
Earth leakage current		mA	< 22		
Nominal current absorbed from mains (at nominal load and battery charged)		A	14	21	26
Maximum current absorbed from mains (at nom. Load, max. recharging current and nominal input voltage)		A	21	28	35
Settable walk-in		sec	Sectable from 5" to 30"		
Settable hold-off		sec	Sectable from 1" to 300"		

## BATTERY

POWER		kVA	10	15	20
Maximum internal battery			60 or 62 batteries 3,3AH - 7,2AH - 9AH		
Standard type			Maintenance free		
Cells number (settable)			2x180 or 2x186		
Floating voltage at 25°C (settable)		Vdc	2x406 or 2x418		
Minimum battery discharge voltage		Vdc	Settable		
Inverter input power (at nominal load)		kW	9.5	14.3	19
Inverter input current (at nominal load and minimum Vdc)		A	13.5	20.5	27
Battery Protection (external to the UPS)			Fuses		
Battery Test			Included as standard		

## UPS OUTPUT: INVERTER

POWER	kVA	10	15	20
Inverter Bridge		Modular IGBT (transformerless)		
Nominal output power (Cosφ 0.9)	kVA	10	15	20
Nominal output power (Cosφ 1.0)	kW	9	13.5	18
Efficiency (DC ÷ AC)	%	> 95		
Output		Three-phase + Neutral		
Nominal output voltage (selectable)	Vac	380-400-415		
Output voltage stability				
- Static (balanced Load)	%	± 1		
- Static (unbalanced Load)	%	± 2		
- Dynamic (step load 20%÷100%÷20%)	%	± 5		
- Output voltage recovery time (after step load)	ms	< 20		
- IEC EN 62040-3		Class 1		
Output frequency (selectable)	Hz	50 - 60		
Output frequency stability				
- Free running quartz oscillator	Hz	± 0,001		
- Inverter sync. with mains	Hz	± 2 (other on request)		
- Slew rate	Hz/s	±1		
Nominal Output Current (@ 400 Vac output)				
- Cosφ 0.9 (leading and lagging)	A	15	22	29
- Cosφ 1 (purely resistive load)		13.5	20	25
Overload capability		125% for 10 min 125%/150% for 30 sec >150% for 10 sec		
Short circuit current	A	24	36	46
Short circuit characteristic		Elect. short circuit protection, current limited at above values. Automatic stop after 5 seconds		
Selectivity		Within ½ cycle (Fuse GL 20% In)		
Output waveform		Sinusoidal		
Output harmonic distortion				
- Linear Load	%	< 1		
- Non Linear Load		< 5		
- IEC EN 62040-3		Fully compliant		
Max crest factor without derating		3 : 1		

---

## UPS OUTPUT: BY PASS

Automatic static by-pass		Electronic thyristor switch
Protection		Fuses
Bypass	Vac	Three-phase + Neutral
Nominal Voltage (selectable) Range	Vac %	380 – 400 – 415 ±10
Nominal Frequency (selectable) Range	Hz %	50-60 ±(1÷5) ±10 adjustable
Transfer mode		Without break
Transfer inverter → automatic bypass		In case of : - Short circuit - Battery end of discharge - Inverter test - Inverter not operating
Retransfer automatic bypass → inverter		- Automatic - Block on bypass after 6 transfers within 2 minutes, reset by front panel
Overload Capability	%	150 continuously 1000 for 1 cycle
Manual By-Pass		Standard: - Electronically controlled - No break
Back feed protection		Standard

---

## OPTIONS

1. BATTERY TEMPERATURE VOLTAGE COMPENSATION
2. INSULATION TRANSFORMER ON BY-PASS
3. VOLTAGE ADAPTATION AUTO-TRANSFORMERS
4. RELAY CARD (Eight signals Alarms/Statuses), Free relay contact
5. SERIAL INTERFACE RS-485 (MOD-BUS protocol)
6. SNMP ADAPTER
7. REMOTE MONITORING PANEL
8. PARALLEL CARD INTERFACE KIT
9. EXTERNAL BATTERY CABINET
10. WALL MOUNTED FUSED SWITCH BOX
11. SPECIAL PAINT
12. LOAD-SYNC BUS CARD INTERFACE KIT
13. DIESEL GENERATOR
14. EXTERNAL EPO AUXILIARY CONTACT
15. EXTERNAL MCB AUXILIARY CONTACT

---

## SOFTWARE ENABLED FUNCTIONS

1. OFF-LINE
2. RECTIFIER WALK-IN TIME
3. RECTIFIER DELAY ON STARTUP (HOLD-OFF TIME)
4. FREQUENCY CONVERTER MODE