



Image for demonstration purposes

**Generating Set  
Base Frame - diesel**

## GE.AI.500/450.BF+011

1500 rpm - Threephase - 50Hz - 400V  
Automatic Panel with AMF without ATS



## Standard equipment

### ⚙️ Exhaust

Exhaust manifold protection  
Silenced muffler -15dB(A)

### ⚙️ Fuel Supply

Single wall daily tank with bunded base  
Automatic shutdown system for low fuel level  
Fuel gauge

### ⚙️ Handling

N.4 lifting hooks integrated into the bearing structure

### ⚙️ Base Frame

Bunded base at 110% of fuel tank capacity  
Anti-vibrating mounting pads

### ⚙️ Engine

High coolant temperature and low oil pressure shutdown system  
Oil pressure and coolant temperature gauge (only with qpe or +14 variant)  
External oil drain points  
Engine liquids (oil and antifreeze)  
Tropicalized radiator  
Rotating parts protection  
Electronic speed governor

### ⚙️ Alternator

Avr automatic voltage regulator  
Avr pre-arranged for parallel  
Impregnation for marine environment  
Ip23

### ⚙️ Panel & connection

Emergency stop button  
Magnetothermal circuit breaker on alternator board  
Cable output from side  
Ip44 wiring  
Start-up battery (pre-charged)  
Grounding point

### ⚙️ Documentation

Ce conformity declaration  
User and maintenance manual  
Wirings diagrams

### ⚙️ Normatives

All generating sets are compliant to CE marking  
2014/30/UE electromagnetic compatibility  
2000/14/CE noise emission for outdoor use  
Factory-designed systems built according to ISO 9001:2015  
CEI EN 60204-1:2018 - Electrical equipment of machines

## Primary data

### General Information

Speed	RPM	<b>1500</b>
Frequency	Hz	<b>50</b>
PRP	KVA	<b>450</b>
Prp - prime power	KW	<b>360,0</b>
Ltp - standby power	KVA	<b>500</b>
Ltp - standby power	KW	<b>400,0</b>
Standard voltage	V	<b>400/230</b>
Current	A	<b>650,3</b>
Cosfi	0,8	<b>0,8</b>

### General electrical protection

Circuit-breaker rated current	A	<b>800</b>
Type		<b>Magnetothermal switch on the alternator board</b>
Circuit-breaker poles	N	<b>4P</b>

### Fuel Consumption

Type		<b>diesel</b>
Standard fuel tank capacity	lt	<b>400</b>
Autonomy @ 75% load	h	<b>6</b>
Fuel consumption at 100% load	lt/h	<b>89,9</b>
Fuel consumption at 75% load	lt/h	<b>72,5</b>
Fuel consumption at 50% load	lt/h	<b>51,8</b>

### General data

Rated capacity	Ah	<b>2x180</b>
Auxiliary voltage	V	<b>24</b>

### Weight and Dimensions

Dimensions (l x w x h)	cm	<b>350x150x195</b>
Weight with liquids (excluding optionals and fuel)	Kg (+/-3%)	<b>3342</b>

## Engine

Factory		<b>FPT</b>
Model		<b>C13TE6W</b>
Emissions stage		<b>Stage 0</b>
Speed governor		<b>Electronic</b>
Radiator	°C	<b>50</b>
Cooling	Tipo	<b>liquid (water + 50% Paraflu11)</b>
Active net power	Kwm	<b>371</b>
Nominal net power	CV	<b>504,1</b>
Cycle	Tipo	<b>4 strokes</b>
Injection	Tipo	<b>Direct</b>
Aspiration	Tipo	<b>Turbo</b>
Numbers of cylinders	N	<b>6</b>
Cylinders arrangement		<b>L</b>
Bore	mm	<b>135</b>
Stroke	mm	<b>150</b>
Total displacement	lt	<b>12,876</b>
Engine oil features		<b>15W40-API CI-4/CH-4 ACEA E5-E7</b>
Engine oil consumption	%	<b>&lt;0,2% fuel consumption</b>
Total oil capacity	lt	<b>60</b>
Total coolant capacity	lt	<b>67</b>

## Alternator

**\* May vary based on stock availability. However, a primary brand will be used.**

Factory		<b>Stamford</b>
Model		<b>S4L1D-G</b>
Prime power prp 3ph+n	KVA	<b>450</b>
Voltage regulator (voltage accuracy)	+/- %	<b>1</b>
Poles	N°	<b>4</b>
Phases	N°	<b>3+N</b>
Standard windings connection		<b>Star Series</b>
Stator/rotor impregnation		<b>H (Outdoor Temp 40°C)</b>
Efficiency	%	<b>93,3</b>
Engine coupling		<b>Elastic disk</b>
Short circuit current		<b>&gt;= 300% (3In)</b>
Protection degree	IP	<b>23</b>
Cooling system		<b>Self ventilating</b>
Maxium overspeed	rpm	<b>2250</b>
Waveform distortion	%	<b>&lt;5</b>
Exciter		<b>Diode bridge</b>

## Standard operating environmental conditions

Ambient temperature	°C	<b>25</b>
Relative humidity	%	<b>30</b>
Max altitude	mt	<b>1000</b>

# Control Systems on board QPE-C-VSC-BF

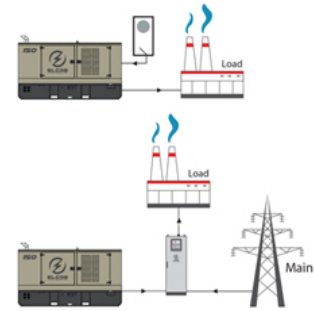

operating scheme - schema di funzionamento

## QPE Automatic panel without switching on board

The QPE-C control panel represents the evolution of the panel for the control and management of the gen set. With its microprocessor logic it is able to meet any user requested features. The dual operation mode manual and automatic guarantees to every type of functionality protection, analysis and control of the generating set in order to make the management easy and efficient. Variant without transfer switch on board. ATS panel type QC as optional. The panel manages the QC panels directly or any other ATS panel.

### Mechanical features

Protection degree	IP	55
-------------------	----	----

### Battery charger

Model		ELCOS - CB1
Maximum output current	A	2,5
Output dc voltage (selectable)	Vdc	12-24
Input ac voltage (selectable)	Vac	220-260
Frequency	Hz	50-60

### Data Communication

Data connection port		RS-485
Communication protocol		Mod-bus RTU-8N1

### Remotable functions in terminal box

Gs start	Gs lock
Genset contactor close/open command	Mains contactor close/open command
Common alarm - dc output	Gs test without load
Gs start with key in off position (only in mrs mode)	Programmable output - volt free output
Management of the automatic fuel refilling system	

## Control Module



Brand	<b>ELCOS</b>
Model	<b>MC4</b>
Operating mode	<b>AMF - MRS</b>

### Specifics

#### Applications

Emergency to the mains  
Stand-alone  
Construction site/rental  
Self-production

#### ENGINE MEASURES

Fuel tank level %  
Engine oil pressure bar (1)  
Engine coolant temperature °c (1)  
Total run time  
Partial run time  
Hours to maintenance  
Battery voltage  
Battery charging voltage  
Start-ups counter  
Engine speed (2)  
Engine oil temperature (2)  
Cooler temperature (2)  
Engine oil level (2)  
Engine coolant level (2)  
Engine coolant pressure (2)  
Turbo pressure (2)  
Fuel consumption (2)  
Tank autonomy - hrs (5)  
Fuel remaining quantity (5)  
Fuel used quantity (5)

#### ALTERNATOR MEASURES

Generator voltage I1, I2, I3  
Generator voltage I1-n, I2-n, I3-n  
Generator frequency  
Generator current I1, I2, I3  
Generator apparent power kva  
Generator active power kw  
Generator reactive power kvar  
Generator accumulated power kwh  
Power factor cosfi

#### MAINS MEASURES

Mains voltage I1, I2, I3  
Mains voltage I1-n, I2-n, I3-n  
Mains frequency

#### COMMUNICATION PORTS

Can-bus port  
Rs485 port with mod-bus rtu communication  
Rs232 port for display connection  
Usb port for parameters saving and firmware update

#### EQUIPMENT

Microprocessor logic  
Back-lit display  
Programmable from display  
16 event log  
Multiple display languages  
Stop button  
Start button  
Test button  
Reset alarm button  
Alarm mute button  
Fuel transfer pump activation button  
Glow-plug activation button

#### PRE-ALARMS/ ALARMS

Common alarm  
Fuel reserve (pre-alarm)  
Low fuel level (alarm)  
Tank overflow  
Charge alternator failed (dinamo)  
Low oil pressure (pre-alarm) (1)  
Low oil pressure (alarm)  
Oil sensor failed (alarm)  
High coolant temperature (pre-alarm) (1)  
High coolant temperature (alarm)  
Low coolant temperature (pre-alarm)  
Low water level (1)  
Water in fuel (1)  
Battery undervoltage  
Battery overvoltage  
Gs failure to start  
Gs failure to stop  
Can-bus failure  
No can-bus communication  
Genset overload I1, I2, I3 phases  
Genset short circuit  
Genset overvoltage  
Genset undervoltage  
Genset high frequency  
Genset low frequency  
Overspeed  
Reverse power  
Earth fault (pre-alarm)  
Earth fault (alarm)  
Block from password  
Can communication failed  
Maintenance request  
Emergency button pressed  
Remote emergency active  
Forced stop  
External battery failed  
Fuel theft  
Genset negative phase sequence  
Mains negative phase sequence  
Fuel theft protection

#### VISUALIZATIONS ON CONTROL MODULE/DISPLAY

Pre-alarms  
Alarms  
Engine measures  
Alternator measures  
Mains measures  
Date and time  
Operating mode  
Genset status  
Mains status  
Mains contactor status  
Genset contactor status  
Digital input and output status  
Grounding current ma (3)  
Grounding current threshold ma (3)  
Delay time of differential protection (3)  
Glow plugs status

#### CONTROL MODULE FUNCTIONS

Automatic start and stop when the mains fails (7)  
Remote start and stop  
Remote start and stop with key in off position  
Manual start and stop  
Emergency stop button on panel board  
Remote emergency stop  
Remote lock  
Remote test without load  
Remote test on load  
Scheduled start-ups  
Modbus commands (start, stop, reset, test)

#### CONTROL MODULE SPECIAL FUNCTIONS (on demand)

Automatic charging of an external battery  
Dummy load (4)  
Load shedding (4)  
Redundant starter motor management  
Fuel monitoring  
Gs battery load test  
Idle mode  
Service phone number indication  
Variable speed generator  
Master / slave mode

## OPTIONAL

### **Canopy Soundproofing**

Air inlet/outlet sound attenuator for room  
Soundproof container of various sizes

### **Exhaust**

Exhaust flexible expansion joint  
External residential muffler  
Exhaust flexible pipe  
(fap) anti-particulate filter  
Exhaust catalyst (cat)

### **Fuel Supply**

Bulk tank connections with 3 way valve  
Bulk tank connections  
Automatic fuel refilling system on board

### **Engine**

Engine pre-heater 230vsuper hot  
Oil change pump  
Engine liquids + 50°C, - 40°C (oil and antifreeze)  
Battery disconnecter  
Automatic refilling oil system  
1000 working hours spare parts kit  
Cyclone air filter  
Redundant start-up battery kit

### **Alternator**

Stator windings thermistors - pt100 - in the alternator box (not managed)  
Bearing thermistor - pt100 - in the alternator box (not managed)  
Anti-condensation heater  
Double bearing  
Three-phase sensing avr  
Bi-phase sensing avr

### **Panel & connection**

Rcd with adjustable current and excludible  
Automatic transfer switch (qc)  
Utf energy meter with arcudi terminal  
Tamperproof panel ip55

### **MC4 optional**

Telemonitoring with software  
Remote panel  
Rs485/usb converter  
Rs485/lan converter  
16 relais card (volt free output)  
Gms modem - sms remote management  
Radiocontrol  
Gsm remote control system with web application without sim card  
Gps tracking system

## PRP

Engines of this rating provide unlimited hours of usage in a variable load application. The average load factor should not exceed 70% of the engine's prime power rating with a maximum number of 500 operational hours at 100% prime power rating. An overload capability of 10% is available, however, is limited to a period of 1 in every 12 hours

## LTP

Limited-time running power is defined as the maximum power available, under the agreed operating conditions, for which the generating set is capable of delivering for up to 500h of operation per year with the maintenance intervals. The overload is not allowed.

Sheet: B3500	OPEN FRAME	Exhaust side:	Type: STANDARD	Rev: 00	Last Update: Mar 20, 2019	Page 1/2
--------------	------------	---------------	----------------	---------	---------------------------	----------

**OVERALL DIMENSIONS [mm]**

REAR VIEW

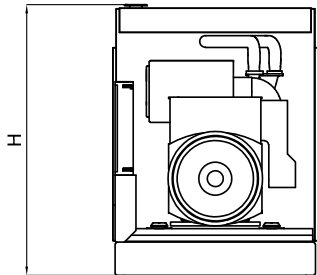

LEFT SIDE VIEW

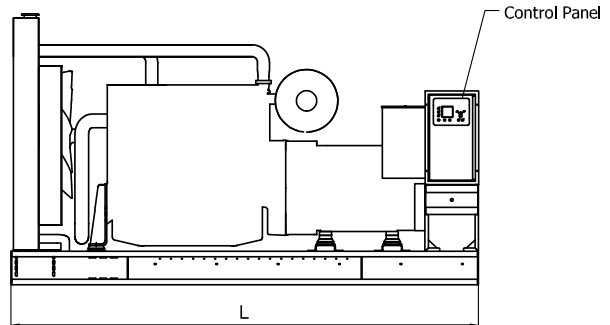

FRONT VIEW

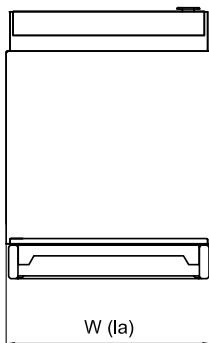

RIGHT SIDE VIEW

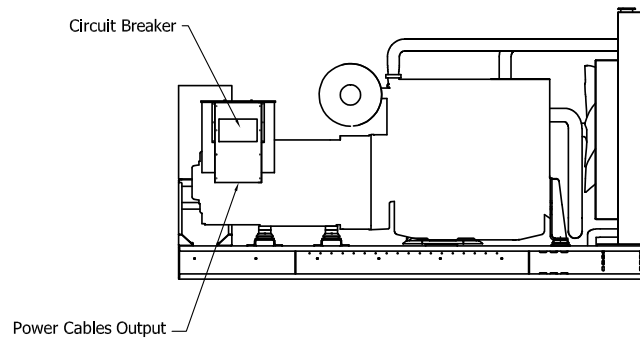

TOP VIEW

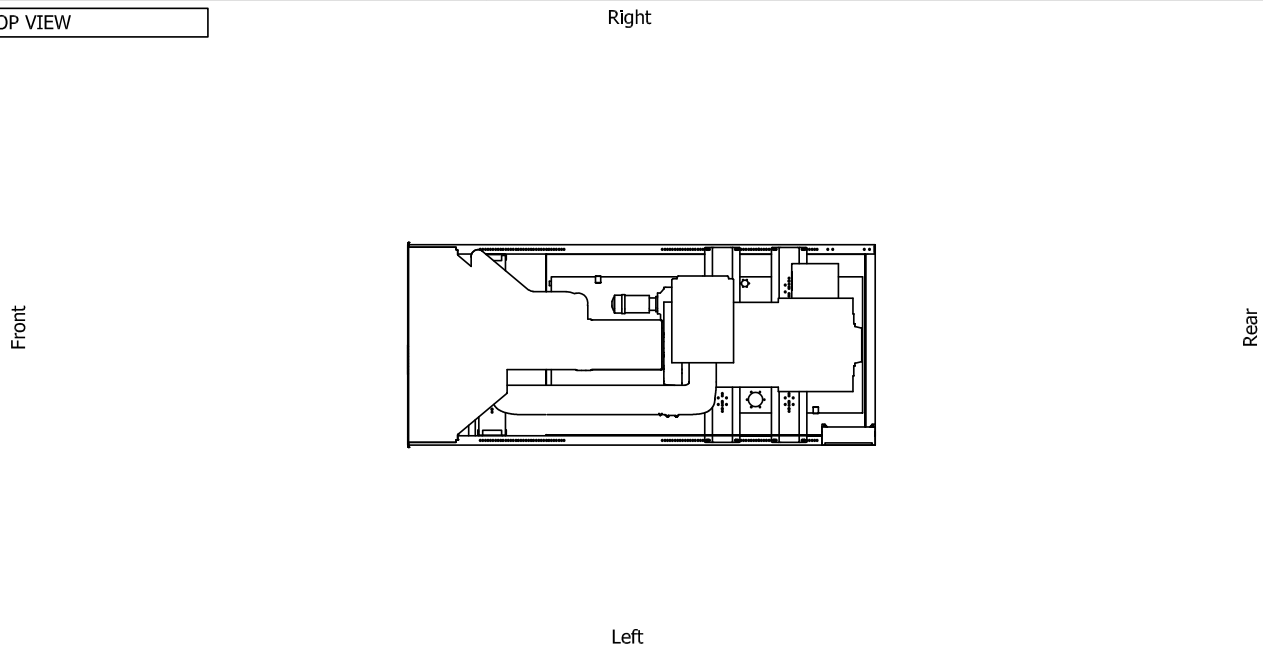

**IMPORTANT:**

- 1) Form and dimension refer to the generating set on catalogue
- 2) Form and dimension are subject to change in order to update or improve the products
- 3) This document can not be copied or trasmitted without ELCOS S.r.l. approval

Sheet:	B3500	OPEN FRAME	Exhaust side:	Type:	STANDARD	Rev:	00	Last Update:	Mar 20, 2019	Page 2/2
--------	-------	------------	---------------	-------	----------	------	----	--------------	--------------	----------

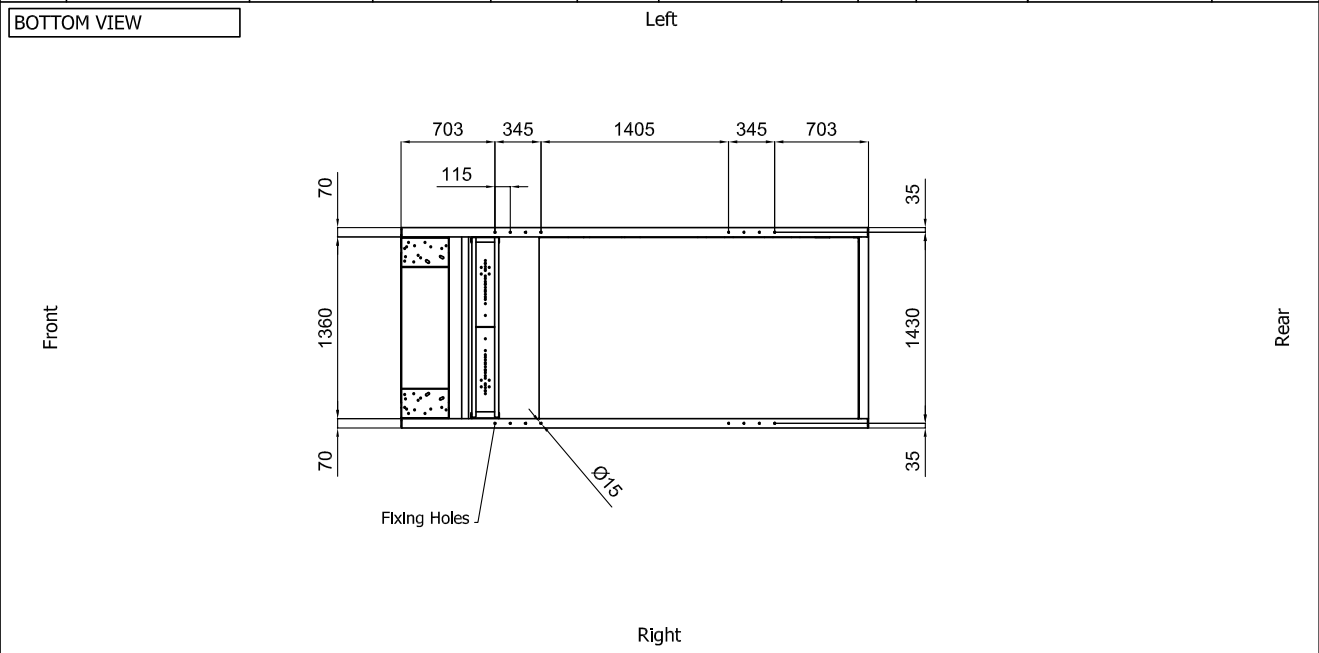

**DIMENSIONS WITH OPEN DOORS [mm]**

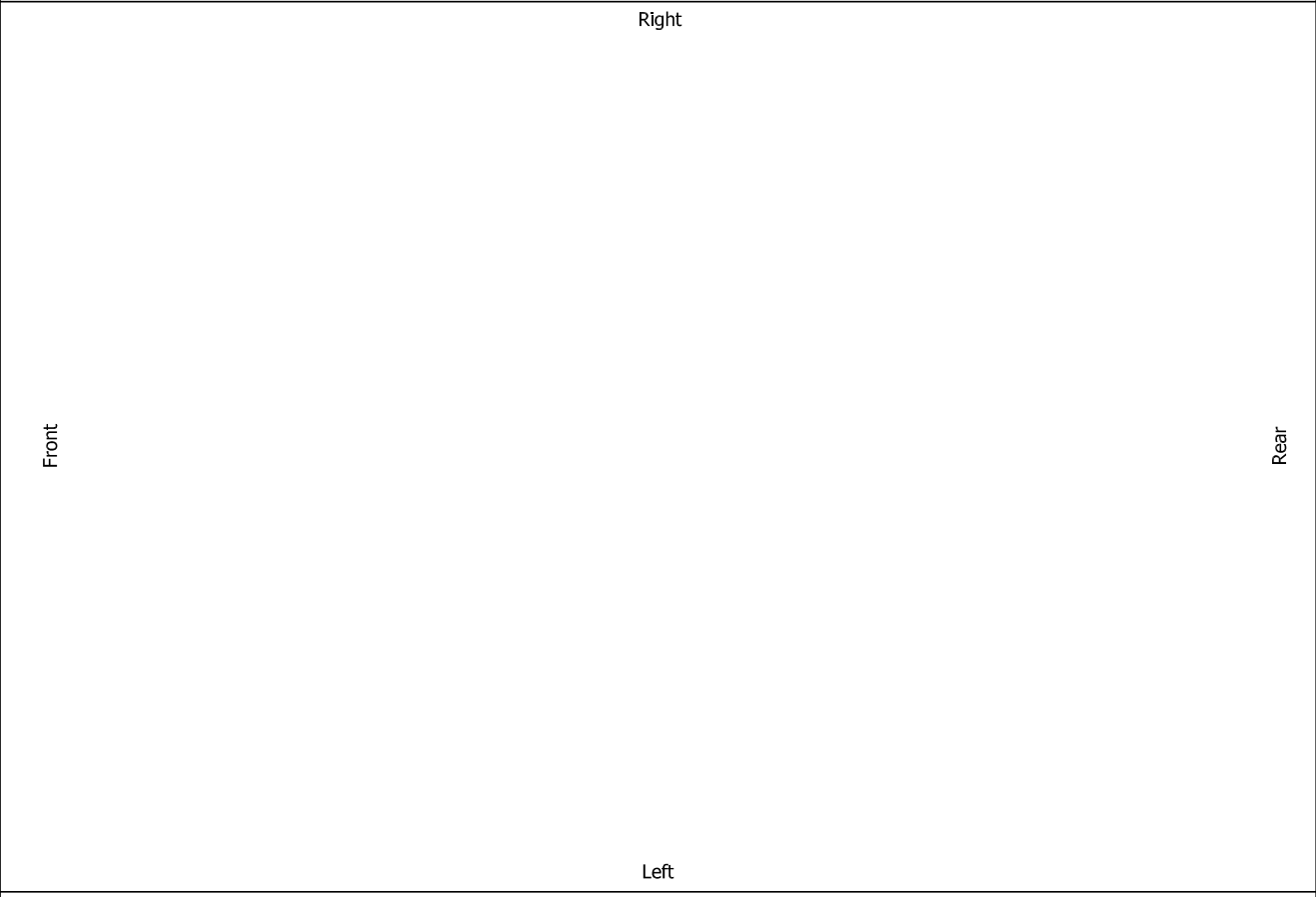

**VENTILATION OF THE ROOM**

The windows area in the generating set room needs to be (recommended):  
 Aspiration: on request  
 Expulsion: on request  
**ATTENTION:** for a correct ventilation the expulsion air and the exhaust gas needs to be conveyed in the open-air

**IMPORTANT:**

- 1) Form and dimension refer to the generating set on catalogue
- 2) Form and dimension are subject to change in order to update or improve the products
- 3) This document can not be copied or trasmitted without ELCOS S.r.l. approval

Data and technical specifications are subject to change in order to update or improve the products.