



Image for demonstration purposes

Generating Set
PROFESSIONAL - Diesel

GE.PK.016/013.PRO+011

1500 rpm - Threephase - 50Hz - 400V
 Multifunction panel without switching on board



Standard equipment

Canopy Soundproofing

Removable soundproof canopy
 Painting canopy (ral) in galvanized sheet steel
 Soundproofing with class 1 polyester material
 Handles with key lock and automatic closing
 Inspection doors for controls and maintenance
 Inspection doors with hermetic gasket

Exhaust

Exhaust rain cap
 Insulated exhaust pipes
 Internal residential muffler

Fuel Supply

Single wall daily tank with bunded base
 Automatic shutdown system for low fuel level
 Fuel gauge

Handling

N.4 lifting hooks integrated into the bearing structure
 Loadable side by side for truck transportation

Base Frame

Anti-vibrating mounting pads
 Anti pollution bunded base

Engine

High coolant temperature and low oil pressure shutdown system
 Engine liquids (oil and antifreeze)
 Tropicalized radiator
 Rotating parts protection

Alternator

Avr automatic voltage regulator
 Impregnation for marine environment
 Ip23

Panel & connection

Emergency stop button
 Tamperproof panel ip55
 Cable output from the bottom
 Ip44 wiring
 Start-up battery (pre-charged)
 Grounding point

Documentation

Ce conformity declaration
 User and maintenance manual
 Wirings diagrams

Normatives

All generating sets are compliant to CE marking
 2014/30/UE electromagnetic compatibility
 2000/14/CE noise emission for outdoor use
 Factory-designed systems built according to ISO 9001:2015
 Cei en 60204-1:2018 - electrical equipment of machines

Primary data

General Information

Speed	RPM	1500
Frequency	Hz	50
PRP	KVA	13
Prp - prime power	KW	10,4
Ltp - standby power	KVA	15
Ltp - standby power	KW	12,0
Standard voltage	V	400/230
Current	A	18,79
Voltage for current calculation	V	400
Cosfi	0,8	0,8

General electrical protection

Circuit-breaker rated current	A	20
Type	Magnetothermal switch on panel board	
Circuit-breaker poles	N	4P

Noise level +/- 3dB(A)

LWA	dB(A)	85
Sound pressure level @ 7 mt	dB(A)	60
Sound pressure level @ 1 mt	dB(A)	69

Fuel Consumption

Type	Diesel	
Standard fuel tank capacity	lt	90
Autonomy @ 75% load	h	33
Fuel consumption at 100% load	lt/h	3,7
Fuel consumption at 75% load	lt/h	2,8
Fuel consumption at 50% load	lt/h	2

General data

Rated capacity	Ah	1x70
Auxiliary voltage	V	12
Exhaust diameter	mm	50

Weight and Dimensions

Dimensions (l x w x h)	cm	173x92x130
Weight with liquids (excluding optionals and fuel)	Kg (+/-3%)	632

Engine

Factory		Perkins
Model		403A-15G1
Emissions stage		Stage 0
Speed governor		Mechanic +/-5%
Radiator	°C	50
Cooling	Tipo	liquid (water + 50% Paraflu11)
Active net power	Kwm	12
Nominal net power	CV	16,3
Cycle	Tipo	4 strokes
Injection	Tipo	Indirect
Aspiration	Tipo	Natural
Numbers of cylinders	N	3
Cylinders arrangement		L
Bore	mm	84
Stroke	mm	90
Total displacement	lt	1,496
Engine oil features		15W40-API CI-4/CH-4 ACEA E5-E7
Total oil capacity	lt	6
Total coolant capacity	lt	6

Alternator

*** May vary based on stock availability. However, a primary brand will be used.**

Factory		Stamford
Model		SOL1-P1
Single-phase range	KVA	15
Voltage regulator (voltage accuracy)	+/- %	1
Poles	N°	4
Phases	N°	3+N
Standard windings connection		Star Series
Stator/rotor impregnation		H (Outdoor Temp 40°C)
Efficiency	%	83,2
Engine coupling		Elastic disk
Short circuit current		>= 300% (3In)
Protection degree	IP	23
Cooling system		Self ventilating
Maxium overspeed	rpm	2250
Waveform distortion	%	<5
Exciter		Diode bridge

Standard operating environmental conditions

Ambient temperature	°C	25
Relative humidity	%	30
Max altitude	mt	1000

Control Systems on board QLE-A-SC-3F-4P-20-01



operating scheme - schema di funzionamento

QLE Multifunction panel without switching on board

The QLE command and control panel offers outstanding protection, monitoring and control for small and middle size generator sets. Elcos's control module MC2 offers advanced features to meet the most demanding on-site application. Elcos's control module MC2 is designed to offer an easy user interface. Variant with transfer switch on board. Switching made with a pair of contacts electrically and mechanically interlocked. The output line is protected by a breaker which protects from overload, short circuit.

Mechanical features

Protection degree	IP	55
-------------------	----	----

Battery charger

Model		ELCOS - CB1
Maximum output current	A	2,5
Output dc voltage (selectable)	Vdc	12-24
Input ac voltage (selectable)	Vac	220-260
Frequency	Hz	50-60

Remotable functions in terminal box

Gs start	Gs lock
Genset contactor close/open command (1)	Mains contactor close/open command (2)
Common alarm - volt free output	Common alarm - dc output
Gs test without load	

- (1) Ready to load function (MRS mode only)
 (2) AMF mode only

Control Module



Brand	ELCOS
Model	MC2
Operating mode	AMF - MRS

Specifics

Applications

Emergency to the mains
Stand-alone

ENGINE MEASURES

Fuel tank level %
Total run time
Battery voltage
Battery charging voltage
Start-ups counter
Engine speed

ALTERNATOR MEASURES

Generator voltage I1, I2, I3
Generator voltage I1-n, I2-n, I3-n
Generator frequency

MAINS MEASURES

Mains voltage I1, I2, I3
Mains voltage I1-n, I2-n, I3-n
Mains frequency

COMMUNICATION PORTS

Configurable via pc using usb port

EQUIPMENT

Microprocessor logic
Back-lit display
Programmable by pc software
10 event log
Icons management
Stop button
Start button
Aut mode button
Reset alarm button

PRE-ALARMS/ ALARMS

Common alarm
Fuel reserve (pre-alarm)
Low fuel level (alarm)
Charge alternator failed (dinamo)
Low oil pressure (alarm)
High coolant temperature (alarm)
Battery undervoltage
Gs failure to start
Gs failure to stop
Genset overvoltage
Genset undervoltage
Genset high frequency
Genset low frequency
Maintenance request
Emergency button pressed

VISUALIZATIONS ON CONTROL MODULE/DISPLAY

Pre-alarms
Alarms
Engine measures
Alternator measures
Mains measures
Operating mode
Genset status
Mains status
Mains contactor status
Genset contactor status

CONTROL MODULE FUNCTIONS

Automatic start and stop when the mains fails (7)
Remote start and stop
Manual start and stop
Emergency stop button on panel board
Remote emergency stop
Remote lock

(7) AMF mode only

OPTIONAL

⚙️ Fuel Supply



O.G-ACO-AT-CI-01

External tank connections for supply only from external tank (g without tank) GE 10/100



O.G-ACO-BT-P1700-400

400 Lt Oversized Fuel Tank on board for BF/PRO (10/20 kVA), (Increased weight and size)



O.G-ACO-ST-BG-ES2

"Easy" automatic fuel refilling system on board, controlled by QST2 for QLE panel

⚙️ Batteries



O.G-BAT-BAE-01

Maintenance free high efficiency starter batteries (10/40 kVA)



O.G-BAT-STB-01

Battery isolator lockable (10/100 kVA)

⚙️ Electrical on board



O.G-USP-16A5P

Output power socket 16A EC 5P (10/13 kVA) for Gen Sets SS Version +011



O.Q-QLE-K-DIF-M1

Fixed differential protection only for MC2 controller for Gen Sets 10/40 kVA (Variant +010 / +011)



O.Q-QLE-QBM-COM-AMF25

Additional price for QBM COMAP AMF25 panel replacing the standard QLE-A.



O.Q-QLE-QBM-DSE-7320

Additional price for QBM DSE7320 panel replacing the standard QLE-A.



O.Q-QLE-QPE-MC4

Additional price for QPE-C panel with MC4 replacing the standard QLE-A.

⚙️ Engine



O.G-MOT-K-40C-01

Engine liquids suitable for -40°C ambient temperature for Gen Sets 10/40 kVA



O.G-MOT-PO-01

Oil change pump for Gen Sets 10/100 kVA



O.G-MOT-SC-AC-EL-01

Engine pre-heater 230V with thermostat on board for Gen Sets 10/100 kVA + 130/250 PRO version



O.G-MOT-SC-AC-EL-02

Super hot engine heater 230V with thermostat on board for Gen Sets 10/100 kVA

⚙️ ATS Panels

QLTS.060A Wall-mounted ATS switching panel 60A 4P (40 kVA 400V - 30 kVA 230V) Dim. 40 x 16 x 40 cm - 12 kg.

Exhaust



O.G-SCA-KS-40 Exhaust flex pipe for drainage (length 3 mt.)

Test



MS.CP-LT-01 FAT - Factory Acceptance Test for single Gen Set from 10 to 100 kVA according to our standard procedures in Elcos factory (max 2 hours - max 4 people - max 1 hour of operation)



MS.CP-SP-01 FAT - Factory Acceptance Test for single custom Gen Set from 10 to 100 kVA max 4 operating hours or parallel system up to 4 units for 1 operating hour, in Elcos factory (max 4 hours - max 4 people)

MS.CP-ST-01 FAT - Factory Acceptance Test for single Gen Set from 10 to 100 kVA according to our standard procedures in Elcos factory (max 4 hours - max 4 people - max 2 hour of operation)

PRP

Engines of this rating provide unlimited hours of usage in a variable load application. The average load factor should not exceed 70% of the engine's prime power rating with a maximum number of 500 operational hours at 100% prime power rating. An overload capability of 10% is available, however, is limited to a period of 1 in every 12 hours

LTP

Limited-time running power is defined as the maximum power available, under the agreed operating conditions, for which the generating set is capable of delivering for up to 500h of operation per year with the maintenance intervals. The overload is not allowed.

Sheet:	PRO1700	PRO	Exhaust side:	-	Type:	STANDARD	Rev:	00	Last Update:	04-02-2020	Page 1/2
--------	---------	-----	---------------	---	-------	----------	------	----	--------------	------------	----------

OVERALL DIMENSIONS [mm]

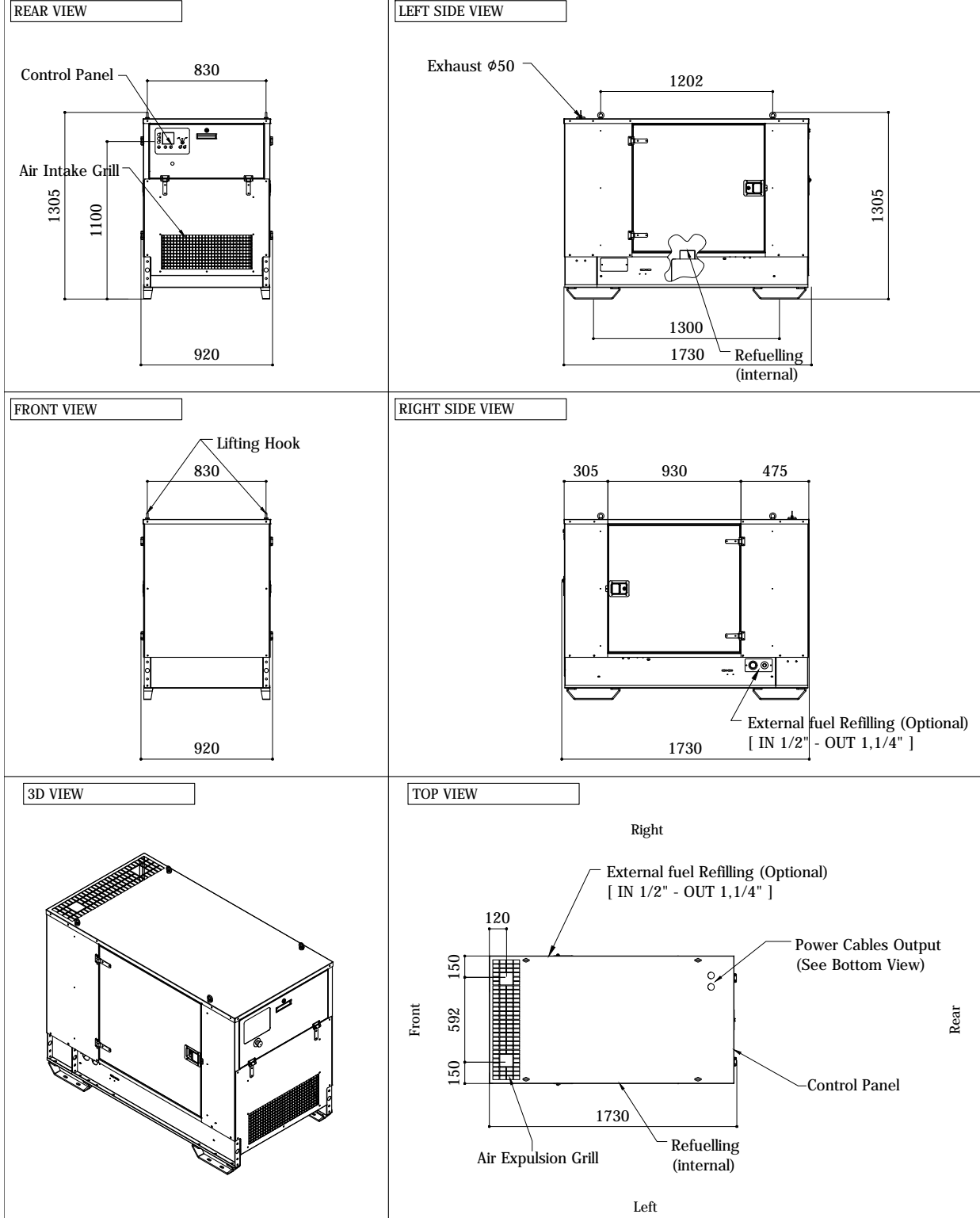

IMPORTANT:

- 1) Form and dimension refer to the generating set on catalogue
- 2) Form and dimension are subject to change in order to update or improve the products
- 3) This document can not be copied or transmitted without ELCOS S.r.l. approval

Sheet:	PRO1700	PRO	Exhaust side:		Type:	STANDARD	Rev:	00	Last Update:	04-02-2020	Page 2/2
--------	---------	-----	---------------	--	-------	----------	------	----	--------------	------------	----------

3D BOTTOM VIEW

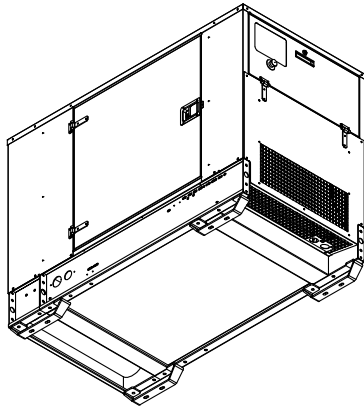

BOTTOM VIEW

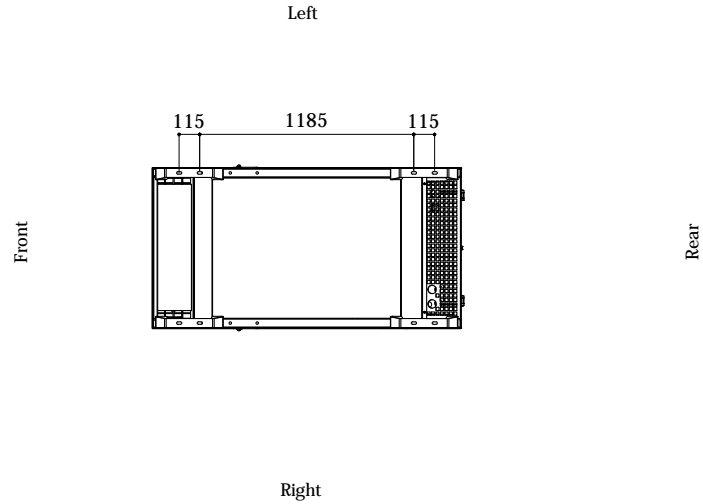

DIMENSIONS WITH OPEN DOORS [mm]

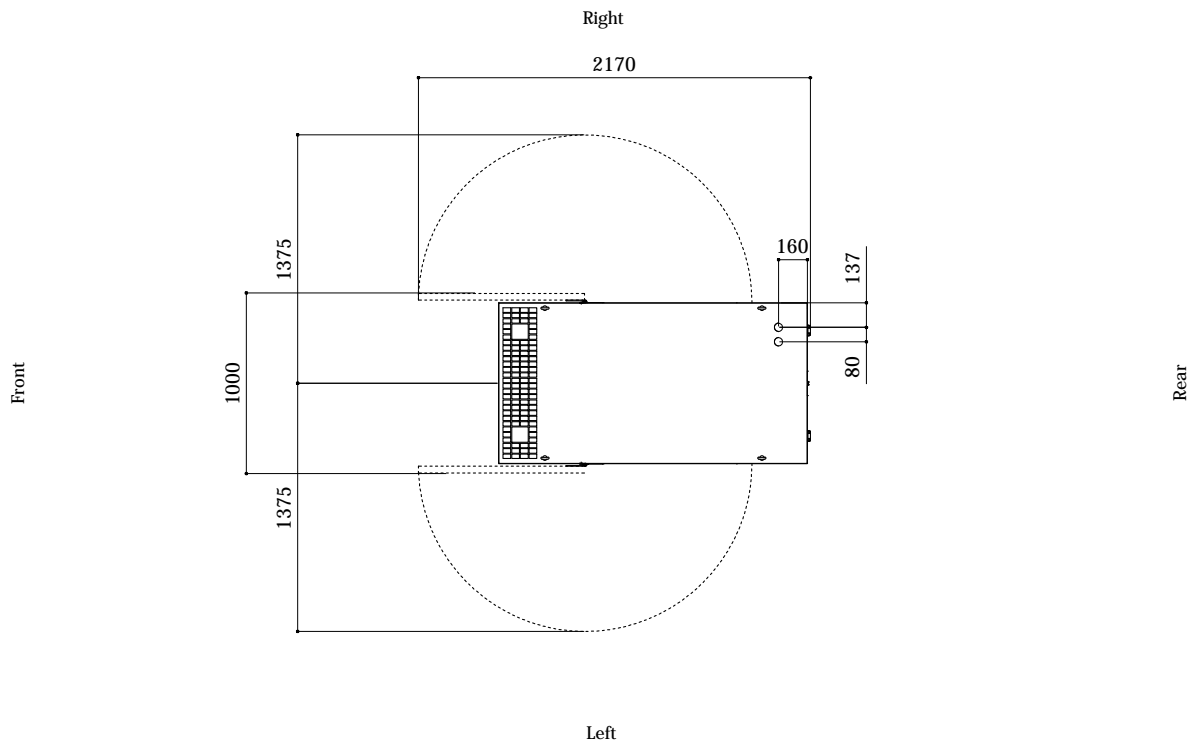

Note: With Lifting-Off Door Solution consider only canopy dimensions.
(Models with "Control Panel" behind rear door will mount a special cover to protect it)

VENTILATION OF THE ROOM

The windows area in the generating set room needs to be (recommended):
Aspiration: 0.26 m²
Expulsion: 0.21 m²
ATTENTION: for a correct ventilation the expulsion air and the exhaust gas needs to be conveyed in the open-air

- IMPORTANT:**
- 1) Form and dimension refer to the generating set on catalogue
 - 2) Form and dimension are subject to change in order to update or improve the products
 - 3) This document can not be copied or transmitted without ELCOS S.r.l. approval