



Image for demonstration purposes

Generating Set Base Frame - diesel

GE.YA.037/033.BF+011

1500 rpm - Threephase - 50Hz - 400V
Automatic Panel with AMF without ATS



Standard equipment

⚙️ Exhaust

Exhaust manifold protection
Silenced muffler -15dB(A)

⚙️ Fuel Supply

Single wall daily tank with bunded base
Automatic shutdown system for low fuel level
Fuel gauge

⚙️ Handling

Base frame with anti-overturning forklift pockets
Forkliftable on the short side

⚙️ Base Frame

Anti-vibrating mounting pads
Battery compartment externally accessible for easy service
Anti pollution bunded base

⚙️ Engine

High coolant temperature and low oil pressure shutdown system
External oil drain points
Engine liquids (oil and antifreeze)
Tropicalized radiator
Rotating parts protection

⚙️ Alternator

Avr automatic voltage regulator
Impregnation for marine environment
Ip23

⚙️ Panel & connection

Emergency stop button
Cable output from the bottom
Ip44 wiring
Start-up battery (pre-charged)
Grounding point

⚙️ Documentation

Ce conformity declaration
User and maintenance manual
Wirings diagrams

⚙️ Normatives

All generating sets are compliant to CE marking
2014/30/UE electromagnetic compatibility
2000/14/CE noise emission for outdoor use
Factory-designed systems built according to ISO 9001:2015
CEI EN 60204-1:2018 - Electrical equipment of machines

Primary data

General Information

Speed	RPM	1500
Frequency	Hz	50
PRP	KVA	33
Prp - prime power	KW	26,4
Ltp - standby power	KVA	37
Ltp - standby power	KW	29,6
Standard voltage	V	400/230
Current	A	47,7
Cosfi	0,8	0,8

General electrical protection

Circuit-breaker rated current	A	50
Type		Magnetothermal switch on panel board
Circuit-breaker poles	N	4P

Fuel Consumption

Type		diesel
Standard fuel tank capacity	lt	85
Autonomy @ 75% load	h	17
Fuel consumption at 100% load	lt/h	7,2
Fuel consumption at 75% load	lt/h	5,2
Fuel consumption at 50% load	lt/h	3,8

General data

Rated capacity	Ah	1x100
Auxiliary voltage	V	12
Exhaust gas temperature	°C	500
Exhaust diameter	mm	50

Weight and Dimensions

Dimensions (l x w x h)	cm	170x80x127
Weight with liquids (excluding optionals and fuel)	Kg (+/-3%)	678

Engine

Factory		Yanmar
Model		4TNV98
Emissions stage		Stage 3A
Speed governor		Mechanic +/-3%
Radiator	°C	50
Cooling	Tipo	liquid (water + 50% Paraflu11)
Active net power	Kwm	30,7
Nominal net power	CV	41,7
Cycle	Tipo	4 strokes
Injection	Tipo	Direct
Aspiration	Tipo	Natural
Numbers of cylinders	N	4
Cylinders arrangement		L
Bore	mm	98
Stroke	mm	110
Total displacement	lt	3,317
Engine oil features		15W40-API CI-4/CH-4 ACEA E5-E7
Total oil capacity	lt	10,5
Total coolant capacity	lt	11

Alternator

*** May vary based on stock availability. However, a primary brand will be used.**

Factory		Stamford
Model		S1L2-J1
Prime power prp 3ph+n	KVA	35
Voltage regulator (voltage accuracy)	+/- %	1
Poles	N°	4
Phases	N°	3+N
Standard windings connection		Star Series
Stator/rotor impregnation		H (Outdoor Temp 40°C)
Efficiency	%	88
Engine coupling		Elastic disk
Short circuit current		>= 300% (3In)
Protection degree	IP	23
Cooling system		Self ventilating
Maxium overspeed	rpm	2250
Exciter		Diode bridge

Standard operating environmental conditions

Ambient temperature	°C	25
Relative humidity	%	30
Max altitude	mt	1000

Control Systems on board QLE-A-OSC-30

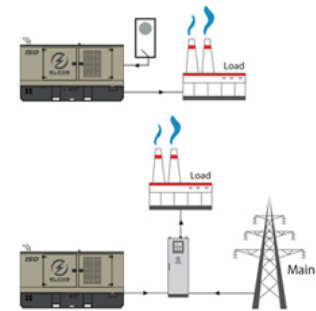

operating scheme - schema di funzionamento

QLE Multifunction panel without switching on board

The QLE command and control panel offers outstanding protection, monitoring and control for small and middle size generator sets. Elcos's control module MC2 offers advanced features to meet the most demanding on-site application. Elcos's control module MC2 is designed to offer an easy user interface. Variant without transfer switch on board. ATS panel type QC as optional. The panel manages the QC panels directly or any other ATS panel. The output line is protected by a breaker which protects from overload, short circuit.

Mechanical features

Protection degree	IP	55
-------------------	----	----

Battery charger

Model		ELCOS - CB1
Maximum output current	A	2,5
Output dc voltage (selectable)	Vdc	12-24
Input ac voltage (selectable)	Vac	220-260
Frequency	Hz	50-60

Remotable functions in terminal box

Gs start	Gs lock
Genset contactor close/open command	Mains contactor close/open command
Common alarm - volt free output	Common alarm - dc output
Gs test without load	

Control Module



Brand	ELCOS
Model	MC2
Operating mode	AMF - MRS

Specifics

Applications

Emergency to the mains
Stand-alone

ENGINE MEASURES

Fuel tank level %
Total run time
Battery voltage
Battery charging voltage
Start-ups counter
Engine speed

ALTERNATOR MEASURES

Generator voltage I1, I2, I3
Generator voltage I1-n, I2-n, I3-n
Generator frequency

MAINS MEASURES

Mains voltage I1, I2, I3
Mains voltage I1-n, I2-n, I3-n
Mains frequency

COMMUNICATION PORTS

Configurable via pc using usb port

EQUIPMENT

Microprocessor logic
Back-lit display
Programmable by pc software
10 event log
Icons management
Stop button
Start button
Aut mode button
Reset alarm button

PRE-ALARMS/ ALARMS

Common alarm
Fuel reserve (pre-alarm)
Low fuel level (alarm)
Charge alternator failed (dinamo)
Low oil pressure (alarm)
High coolant temperature (alarm)
Battery undervoltage
Gs failure to start
Gs failure to stop
Genset overvoltage
Genset undervoltage
Genset high frequency
Genset low frequency
Maintenance request
Emergency button pressed
Genset negative phase sequence

VISUALIZATIONS ON CONTROL MODULE/DISPLAY

Pre-alarms
Alarms
Engine measures
Alternator measures
Mains measures
Operating mode
Genset status
Mains status
Mains contactor status
Genset contactor status

CONTROL MODULE FUNCTIONS

Automatic start and stop when the mains fails (7)
Remote start and stop
Manual start and stop
Emergency stop button on panel board
Remote emergency stop
Remote lock

OPTIONAL

Canopy Soundproofing

Soundproofed container 65 dB(A) @ 7 mt
Soundproofed container 55 dB(A) @ 7 mt and 60/62 dB(A) @ 1mt"
Air inlet/outlet sound attenuator for room

Exhaust

Exhaust flexible expansion joint
External residential muffler
Exhaust flexible pipe
(fap) anti-particulate filter
Exhaust catalyst (cat)

Fuel Supply

Bulk tank connections with 3 way valve
Bulk tank connections
Automatic fuel refilling system on board

Engine

Engine pre-heater 230vsuper hot
Oil pressure and coolant temperature gauge (only with qpe or +14 variant)
Oil change pump
Engine liquids + 50°C, - 40°C (oil and antifreeze)
Battery disconnecter
Automatic refilling oil system
1000 working hours spare parts kit
Cyclone air filter
Redundant start-up battery kit

Alternator

Avr pre-arranged for parallel
Anti-condensation heater

Panel & connection

Rcd block
Automatic transfer switch (qc)
Elcos polyvalent panel (qpe)

PRP

Engines of this rating provide unlimited hours of usage in a variable load application. The average load factor should not exceed 70% of the engine's prime power rating with a maximum number of 500 operational hours at 100% prime power rating. An overload capability of 10% is available, however, is limited to a period of 1 in every 12 hours

LTP

Limited-time running power is defined as the maximum power available, under the agreed operating conditions, for which the generating set is capable of delivering for up to 500h of operation per year with the maintenance intervals. The overload is not allowed.

Sheet:	GE.25.40.PROV.BF	OPEN FRAME	Exhaust side:	Type:	STANDARD	Rev:	01	Last Update:	Feb 02, 2014	Page 1/2
--------	------------------	------------	---------------	-------	----------	------	----	--------------	--------------	----------

OVERALL DIMENSIONS [mm]

REAR VIEW

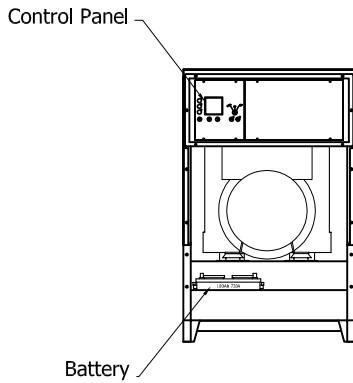

LEFT SIDE VIEW

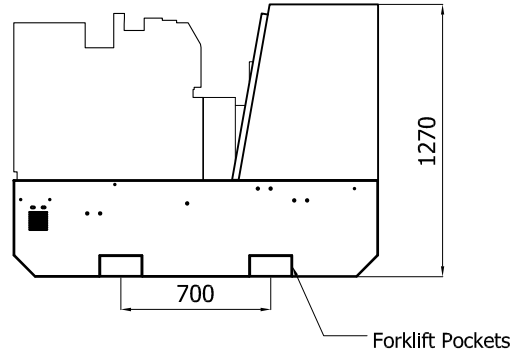

FRONT VIEW

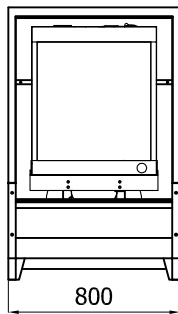

RIGHT SIDE VIEW

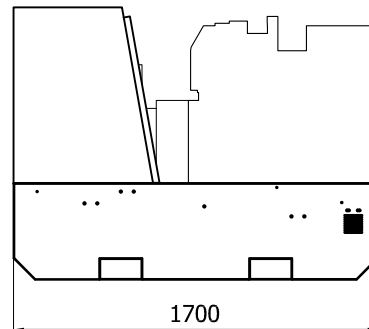

TOP VIEW

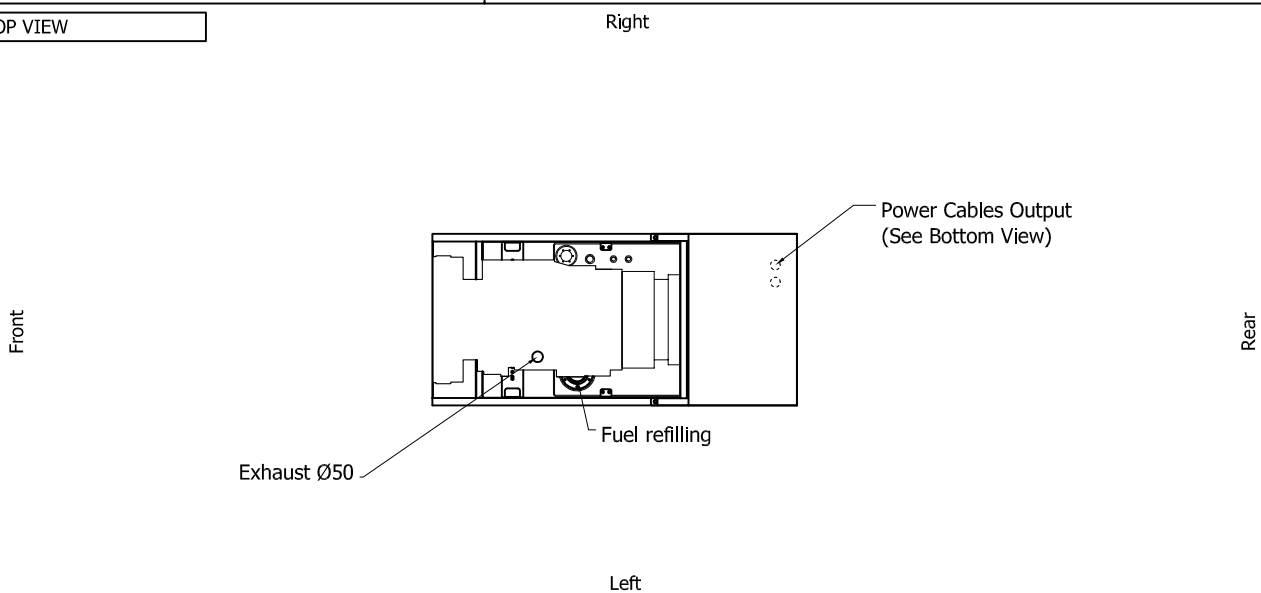

IMPORTANT:

- 1) Form and dimension refer to the generating set on catalogue
- 2) Form and dimension are subject to change in order to update or improve the products
- 3) This document can not be copied or transmitted without ELCOS S.r.l. approval

Sheet:	GE.25.40.PROV.BF	OPEN FRAME	Exhaust side:		Type:	STANDARD	Rev:	01	Last Update:	Feb 02, 2014	Page 2/2
--------	------------------	------------	---------------	--	-------	----------	------	----	--------------	--------------	----------

BOTTOM VIEW

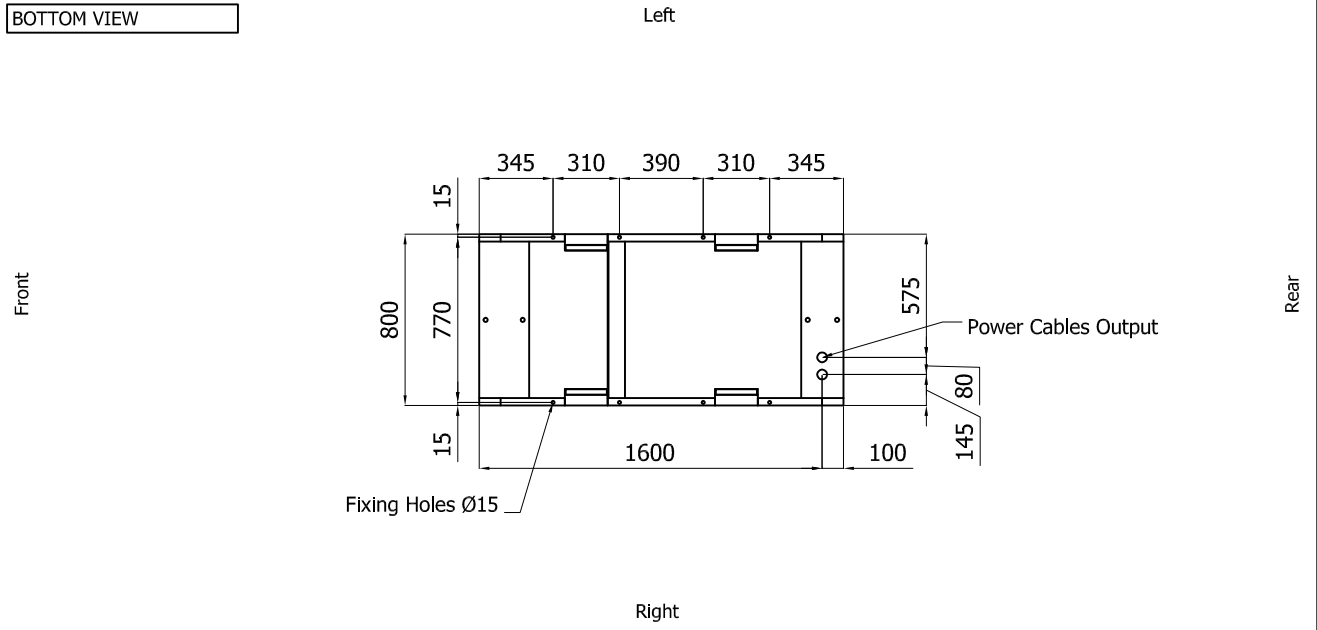

DIMENSIONS WITH OPEN DOORS [mm]

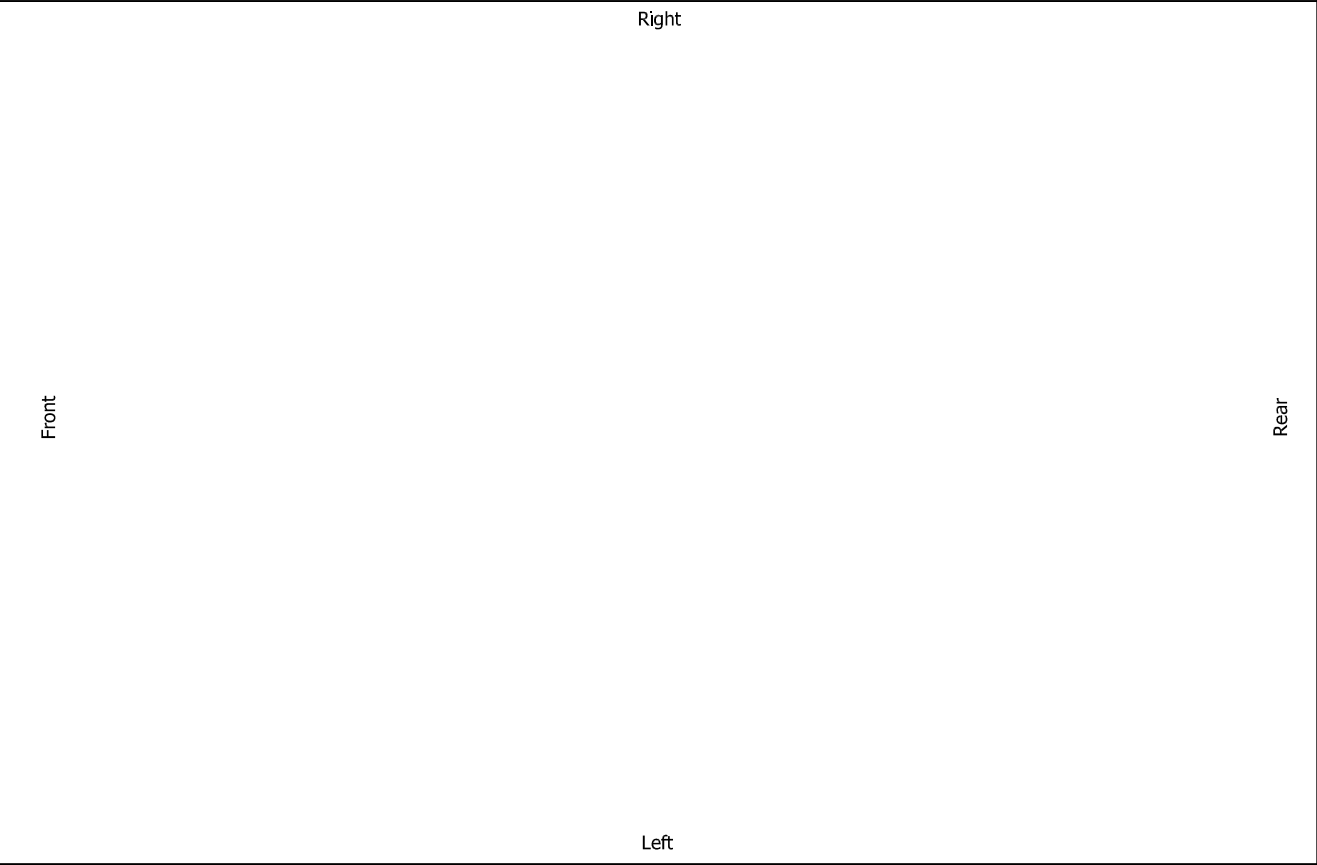

VENTILATION OF THE ROOM

The windows area in the generating set room needs to be (recommended):
 Aspiration: on request
 Expulsion: on request
 ATTENTION: for a correct ventilation the expulsion air and the exhaust gas needs to be conveyed in the open-air

IMPORTANT:

- 1) Form and dimension refer to the generating set on catalogue
- 2) Form and dimension are subject to change in order to update or improve the products
- 3) This document can not be copied or trasmitted without ELCOS S.r.l. approval

Data and technical specifications are subject to change in order to update or improve the products.